

K2 Armor 3in Drop N Lock, Kit



 DATA SHEET



PRODUCT FEATURES



/Roof attachment optimized for flat roof installations

/Can be installed to the rafter (2 screws) or decking (6 screws)

/Redundant waterproofing with K2 EverSeal preassembled on Drop N Lock and Armor

/One pouch of Seal Bond 490 liquid (2L) will fill 6 K2 Armor 3"

TECHNICAL DATA

	K2 Armor 3in Drop N Lock, Kit
Part Number	4000564
Roof Type	TPO, rolled asphalt, concrete and EPDM membrane
Compatibility	CrossRail 44-X, CrossRail 44-X Max, CrossRail 48-X, CrossRail 80
Material	<ul style="list-style-type: none">• Armor: PA 6.6 GF35 UV Resistant• K2 Drop N Lock: Cast Aluminum• K2 EverSeal
Roof Connection	<ul style="list-style-type: none">• Armor: K2 EverSeal and Seal Bond 490• Drop N Lock: #14x 3in x 5-16in Hex Head Screw
Certification	TAS 100 and Wind Driven Rain Test
Box Quantity	(6) K2 Armor 3" (6) Drop N Lock 6" (6) Slotted L Feet (6) M8x20 bolts (1) SealBond 490 1 ltr Pouch & nozzle

Units: mm [in]

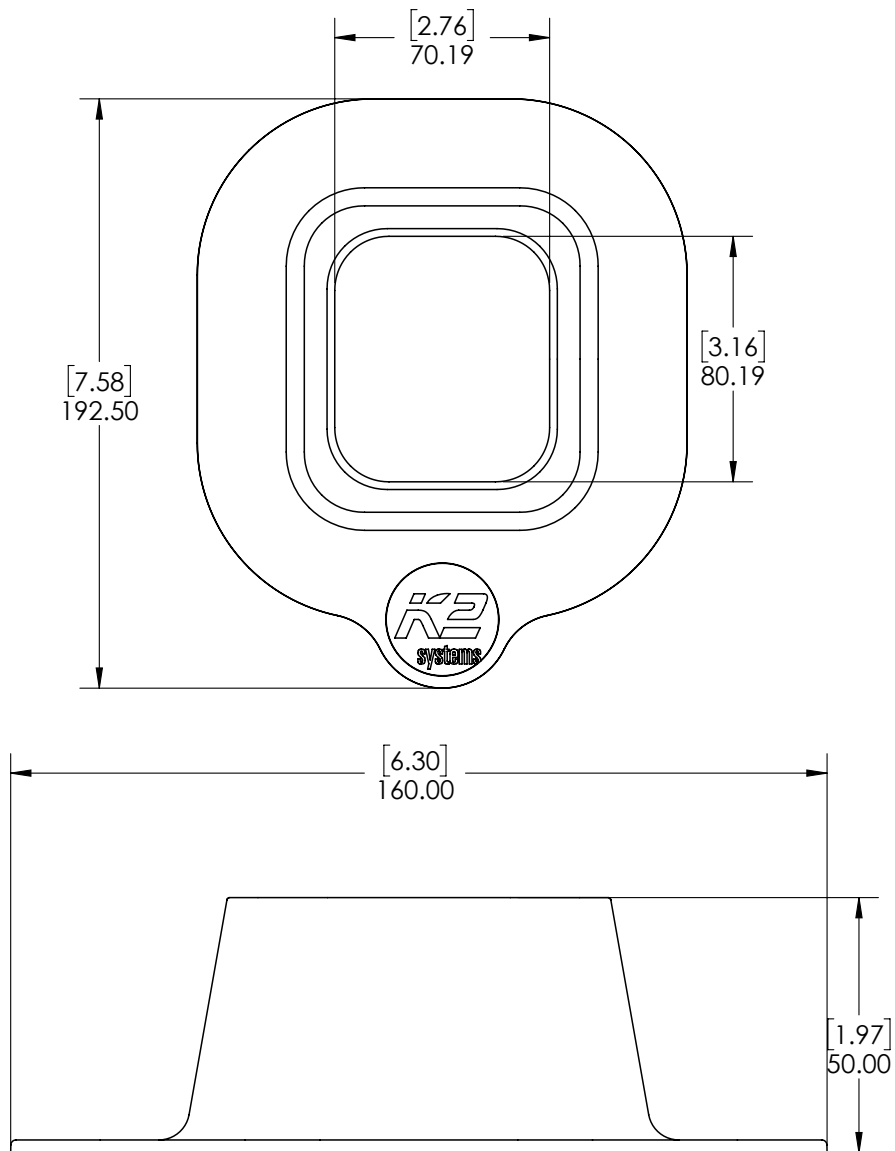

Components

- 1 4000564
K2 Armor 3in Drop N Lock, Kit





Connecting Strength

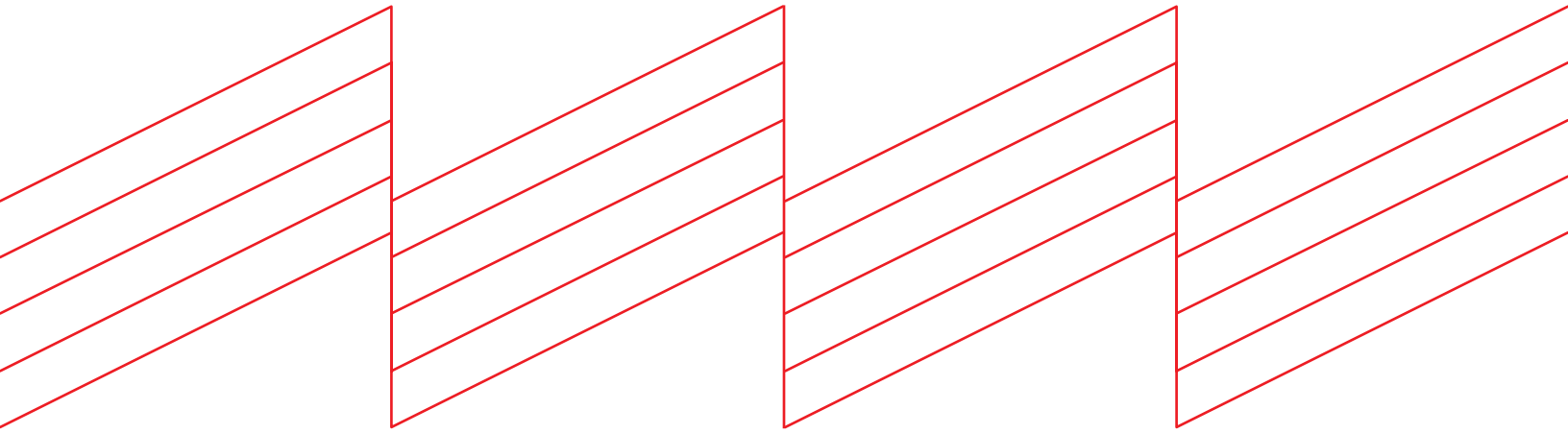

K2 Systems, LLC
4665 North Ave. Suite I • Oceanside, CA 92056-
USA +1.760.301.5300 • infous@k2-systems.com
www.k2-systems.com/en.us

K2 Armor 3in Drop N Lock, Kit • Data Sheet V1 | 0825 • Subject to change
Product illustrations are exemplary and may differ from the original.